

Fire Test for Quarter-turn Valves and Valves Equipped with Nonmetallic Seats

API STANDARD 607
EIGHTH EDITION, OCTOBER 2022



Special Notes

API publications necessarily address problems of a general nature. With respect to particular circumstances, local, state, and federal laws and regulations should be reviewed. The use of API publications is voluntary. In some cases, third parties or authorities having jurisdiction may choose to incorporate API standards by reference and may mandate compliance.

Neither API nor any of API's employees, subcontractors, consultants, committees, or other assignees make any warranty or representation, either express or implied, with respect to the accuracy, completeness, or usefulness of the information contained herein, or assume any liability or responsibility for any use, or the results of such use, of any information or process disclosed in this publication. Neither API nor any of API's employees, subcontractors, consultants, or other assignees represent that use of this publication would not infringe upon privately owned rights.

API publications may be used by anyone desiring to do so. Every effort has been made by the Institute to ensure the accuracy and reliability of the data contained in them; however, the Institute makes no representation, warranty, or guarantee in connection with this publication and hereby expressly disclaims any liability or responsibility for loss or damage resulting from its use or for the violation of any authorities having jurisdiction with which this publication may conflict.

API publications are published to facilitate the broad availability of proven, sound engineering and operating practices. These publications are not intended to obviate the need for applying sound engineering judgment regarding when and where these publications should be used. The formulation and publication of API publications is not intended in any way to inhibit anyone from using any other practices.

Any manufacturer marking equipment or materials in conformance with the marking requirements of an API standard is solely responsible for complying with all the applicable requirements of that standard. API does not represent, warrant, or guarantee that such products do in fact conform to the applicable API standard. Users of this standard should not rely exclusively on the information contained in this document. Sound business, scientific, engineering, and safety judgment should be used in employing the information contained herein.

Neither API nor any of API's employees, subcontractors, consultants, or other assigns make any warranty or representation, either express or implied, with respect to the accuracy, completeness, or utility of the information contained herein, or assume any liability or responsibility for any use, or the results of such use, of any information or process disclosed in this publication, or represent that its use would not infringe upon privately owned rights.

Users of this standard should not rely exclusively on the information contained in this document. Sound business, scientific, engineering, and safety judgment should be used in employing the information contained herein.

API is not undertaking to meet the duties of employers, manufacturers, or suppliers to warn and properly train and equip their employees, and others exposed, concerning health and safety risks and precautions, nor undertaking their obligations to comply with authorities having jurisdiction.

All rights reserved. No part of this work may be reproduced, translated, stored in a retrieval system, or transmitted by any means, electronic, mechanical, photocopying, recording, or otherwise, without prior written permission from the publisher. Contact the Publisher, API Publishing Services, 200 Massachusetts Avenue, NW, Suite 1100, Washington, DC 20001-5571.

Foreword

Nothing contained in any API publication is to be construed as granting any right, by implication or otherwise, for the manufacture, sale, or use of any method, apparatus, or product covered by letters patent. Neither should anything contained in the publication be construed as insuring anyone against liability for infringement of letters patent.

The verbal forms used to express the provisions in this document are as follows.

Shall: As used in a standard, “shall” denotes a minimum requirement to conform to the standard.

Should: As used in a standard, “should” denotes a recommendation or that which is advised but not required to conform to the standard.

May: As used in a standard, “may” denotes a course of action permissible within the limits of a standard.

Can: As used in a standard, “can” denotes a statement of possibility or capability.

This document was produced under API standardization procedures that ensure appropriate notification and participation in the developmental process and is designated as an API standard. Questions concerning the interpretation of the content of this publication or comments and questions concerning the procedures under which this publication was developed should be directed in writing to the Director of Standards, American Petroleum Institute, 200 Massachusetts Avenue, NW, Suite 1100, Washington, DC 20001. Requests for permission to reproduce or translate all or any part of the material published herein should also be addressed to the director.

Generally, API standards are reviewed and revised, reaffirmed, or withdrawn at least every five years. A one-time extension of up to two years may be added to this review cycle. Status of the publication can be ascertained from the API Standards Department, telephone (202) 682-8000. A catalog of API publications and materials is published annually by API, 200 Massachusetts Avenue, NW, Suite 1100, Washington, DC 20001.

Suggested revisions are invited and should be submitted to the Standards Department, API, 200 Massachusetts Avenue, NW, Suite 1100, Washington, DC 20001, standards@api.org.

Contents

	Page
1	Scope..... 1
2	Normative References 1
3	Terms and Definitions 1
4	Test Conditions 2
4.1	Direction and Conditions for Valves to Be Tested 2
4.2	Pressure Relief Provision 2
5	Fire Test Method 3
5.1	General Warning..... 3
5.2	Principle 3
5.3	Apparatus 3
5.4	Test Fluid 6
5.5	Test Fuel 6
5.6	Procedure 6
6	Performance 9
6.1	General 9
6.2	Through-seat Leakage during Burn Period..... 9
6.3	External Leakage during Burn and Cooldown Periods 10
6.4	Low-pressure Test Through-seat Leakage after Cooldown 10
6.5	Operability..... 10
6.6	External Leakage Following Operational Test..... 10
6.7	Test Report 11
7	Qualification of Other Valves by Representative Size, Pressure Rating, and Materials of Construction 12
7.1	General 12
7.2	Materials of Construction 12
7.3	Qualification of Valves by Nominal Size..... 13
7.4	Qualification of Valves by Pressure Rating 13
	Annex A (informative) External Leakage Only Modified Test Procedures 15
	Bibliography..... 16

Figures

1	Recommended Systems..... 5
2	Calorimeter Cube Design and Dimensions..... 6
3	Location of Temperature Measurement Sensors—Nonmetallic Seated Valves up to DN 100 (NPS 4), NPS 4, Class 150, and Class 300 8
4	Location of Temperature Measurement Sensors for All Other Valves (Not Described in Figure 3) 9

Contents

Page

Tables

1	Maximum Leak Rates	10
2	Other Valves Qualified by DN	13
3	Other Valves Qualified by NPS	13
4	Other Valves Qualified by Class	14

Introduction

This standard covers the requirements and method for evaluating the performance of valves when they are exposed to defined fire conditions. The performance requirements establish limits of acceptability of a valve, regardless of size or pressure rating. The burn period has been established to represent the maximum time required to extinguish most fires. Fires of longer duration are considered to be of major magnitude with consequences greater than those anticipated in the test. The test pressure during the burn is set at 0.2 MPa (30 psig) for nonmetallic seated valves rated Class 150 and Class 300 to better simulate the conditions that would be expected in a process plant when a fire is detected and pumps are shut down. In this case, the source of pressure in the system is the hydrostatic head resulting from liquid levels in towers and vessels. This situation is approximated by this lower test pressure.

In production facilities, valves are typically of a higher rating and the pressure source is not easily reduced when a fire is detected. Therefore, for all other valves, the test pressure during the burn is set at a higher value to better simulate the expected service conditions in these facilities. Use of this standard assumes that the execution of its provisions is entrusted to appropriately qualified and experienced personnel because it calls for procedures that may be injurious to health if adequate precautions are not taken. This standard refers only to technical suitability and does not absolve the user from legal obligations relating to health and safety at any stage of the procedure.

Fire Test for Quarter-turn Valves and Valves Equipped with Nonmetallic Seats

1 Scope

This standard specifies fire testing requirements and method for confirming the pressure-containing capability of quarter-turn valves with nonmetallic or metallic seat(s) and other operated valves with nonmetallic seating under pressure during and after the fire test. It does not cover the testing requirements for valve actuators other than manually operated gear boxes or similar mechanisms when these form part of the normal valve assembly. Other types of valve actuators (e.g. electrical, pneumatic, or hydraulic) may need special protection to operate in the environment considered in this valve test, and the fire testing of such actuators is outside the scope of this standard.

2 Normative References

The following documents are referred to in the text in such a way that some or all of their content constitutes requirements of this document. For dated references, only the edition cited applies. For undated references, the latest edition of the referenced document (including any addenda) applies.

API Standard 598, *Valve Inspection and Testing*

IEC 60584–2, *Thermocouples: Tolerance Values of the Thermoelectric Voltages*

3 Terms and Definitions

For the purposes of this document, the following terms and definitions apply.

3.1

asymmetric seated valve

Valve with an internal construction that has no plane of symmetry perpendicular to the axis of the body ends.

NOTE This is a valve with a single seat offset from the shaft centerline.

3.2

Class

An alphanumeric designation that is used for reference purposes related to valve pressure-temperature capability, taking into account valve material mechanical properties and valve dimensional characteristics. It comprises the word “Class” followed by a dimensionless whole number. The number following the word “Class” does not represent a measurable value and is not used for calculation purposes except where specified in this standard. The allowable pressure for a valve having a class number depends on the valve material and its application temperature and is to be found in tables of pressure-temperature ratings.

3.3

DN

An alphanumeric designation of size that is common for components used in a piping system, used for reference purposes, comprising the letters “DN” followed by a dimensionless number indirectly related to the physical size of the bore or outside diameter of the end connection as appropriate. The dimensionless number following “DN” does not represent a measurable value and is not used for calculation purposes except where specified in this standard.

3.4

NPS

An alphanumeric designation of size that is common for components used in a piping system, used for reference purposes, comprising the letters “NPS” followed by a dimensionless number indirectly related to the physical size of the bore or outside diameter of the end connection as appropriate. The dimensionless number may be used as

a valve size identifier without the prefix "NPS." The dimensionless size identification number does not represent a measurable value and is not used for calculation purposes.

3.5

pressure-retaining envelope

Composed of:

- a) the body;
- b) the bonnet, cover, or body-end;
- c) the bolting used to assemble the parts (a) and (b) above.

3.6

symmetric seated valve

Valve with an internal construction that has a plane of symmetry perpendicular to the axis of the body ends.

NOTE This is a valve in which both seat-sealing elements are identical.

4 Test Conditions

4.1 Direction and Conditions for Valves to Be Tested

4.1.1 Symmetric seated valves intended by the manufacturer for bidirectional installation shall be tested in one direction only.

4.1.2 Asymmetric seated valves intended by the manufacturer for bidirectional installation shall be tested by carrying out the burn test procedure twice: once in each direction of the potential installation. The same valve may be refurbished and retested, or another identical valve may be tested in the other direction.

4.1.3 Valves intended solely for unidirectional installation shall be clearly and permanently marked as such and shall be tested in the stated direction of installation.

4.1.4 If the valve being tested is fitted with a gearbox or other such manual device, then only that particular assembly shall qualify. If a valve can be supplied with or without a gearbox, testing with a gearbox fitted shall qualify valves without a gearbox but not the converse. For safety purposes, grease may be removed from a gearbox prior to testing.

4.1.5 Valves (and gearboxes) shall not be protected with insulation material of any form during testing, except where such protection is part of the design of the component(s).

4.1.6 Prior to initiating the test, inspection requirements and testing by the valve manufacturer shall have been completed on the valve in accordance with API Standard 598 or applicable production testing.

4.2 Pressure Relief Provision

If the valve under test incorporates a pressure relief device as part of its standard design and if this device activates during the fire test, then the test shall be continued, and any leakage to atmosphere from the device shall be measured and counted as external leakage. If the design is such that the device vents to the downstream side of the valve, then any leakage shall be counted as through-seat leakage (see 5.6.12 and 5.6.14). However, the test shall be stopped if the system pressure relief device described in 5.3.2 h) activates.

5 Fire Test Method

5.1 General Warning

Fire testing of valves is potentially hazardous, and it is essential that the safety of personnel be given prime consideration. Given the nature of the fire test and the possibility of weaknesses in the design of the test valve and test equipment, hazardous rupture of the pressure boundary could occur. Adequate shields in the area of the test enclosure and other appropriate means for the protection of personnel are necessary.

5.2 Principle

A closed valve completely filled with water under pressure is completely enveloped in flames with an environmental temperature in the region of the valve of 750 °C to 1000 °C (1400 °F to 1800 °F) for a period of 30 minutes. The objective is to completely envelop the valve in flames to ensure that the seat and sealing areas are exposed to the high burn temperature. The intensity of the heat input shall be monitored using thermocouples and calorimeter cubes as specified in 5.6.9 and 5.6.10. During this period, the internal and external leakage is recorded. After cooldown from the fire test, the valve is tested to assess the pressure-containing capability of the valve shell, seats, and seals.

5.3 Apparatus

5.3.1 General

The test equipment shall not subject the valve to externally applied stress affecting the results of the test. Schematic diagrams of recommended systems for fire testing of valves are given in Figure 1. Potential pipework-to-valve end connection joint leakage is not evaluated as part of the test and is not included in the allowable external leakage (see 6.3 and 6.6). For the purposes of this test, it may be necessary to modify these joints to eliminate leakage. The test equipment shall be designed so that if the nominal diameter of the pipework situated immediately upstream of the test valve is larger than DN 25 (NPS 1) or one-half the DN of the test valve, the pipework shall be enveloped in flames for a minimum distance of 150 mm (6 in.) from the test valve. The diameter of the upstream pipework shall be sufficient to deliver a flow rate in excess of the maximum allowable leak rate for the size of the valve being tested. The pipework downstream of the test valve shall be at least DN 15 (NPS ½) and shall be inclined so that the downstream side is fully drained. The flame source shall be at least 150 mm (6 in.) away from the valve or any calorimeters and should have sufficient capacity to completely envelop the valve in flames. The enclosure containing the valve shall provide a horizontal clearance of a minimum of 150 mm (6 in.) between any part of the test valve and the enclosure, and the height of the enclosure above the top of the test valve shall be a minimum of 150 mm (6 in.).

5.3.2 Specific Apparatus

- a) *Vapor trap* to minimize the cooling effect of the upstream liquid (see key item 8 in Figure 1).
- b) *Industrial pressure measurement devices* having a full-scale reading of between 1.5 and 4 times the pressure being measured. The accuracy of each test device used at any point on the scale shall be within 3 % of its maximum scale value for readings taken both up and down the scale with either increasing or decreasing pressure (see key items 7 and 14 in Figure 1).
- c) *Calorimeter cubes* made of carbon steel in accordance with the design and dimensions shown in Figure 2, with a thermocouple of the accuracy specified in 5.3.2 d), located in the center of each cube. Calorimeter cubes shall be scale-free before exposure to the fire environment.
- d) *Flame environment and valve body thermocouples* of an accuracy at least equal to tolerance Class 2 for type B or tolerance Class 3 for other types as specified in IEC 60584-2 (see key item 13 in Figure 1).
- e) *Containers* of a size suitable for collecting the water leaked from the valve under test (see key item 18 in Figure 1).

- f) *Calibrated sight gauge* or device for measuring the water used during the test (see key item 4 in Figure 1).
- g) *Calibrated device for measuring the leakage water* collected during the test.
- h) *Pressure relief provision*, incorporated in the system, consisting of a pressure relief valve to relieve the test valve center cavity pressure to the atmosphere and to protect against potential rupture of the valve if it is designed such that liquid can be trapped in the cavity (see key item 14 in Figure 1). The pressure relief valve setting shall be either a) that determined by the valve manufacturer or b) when pressure test data are not available, a setting not greater than 1.5 times the maximum allowable working pressure at 20 °C (70 °F). The maximum allowable working pressure depends on materials, design, and working temperatures and is to be selected from the tables of pressure-temperature ratings given in the appropriate standards such as ASME B16.34.

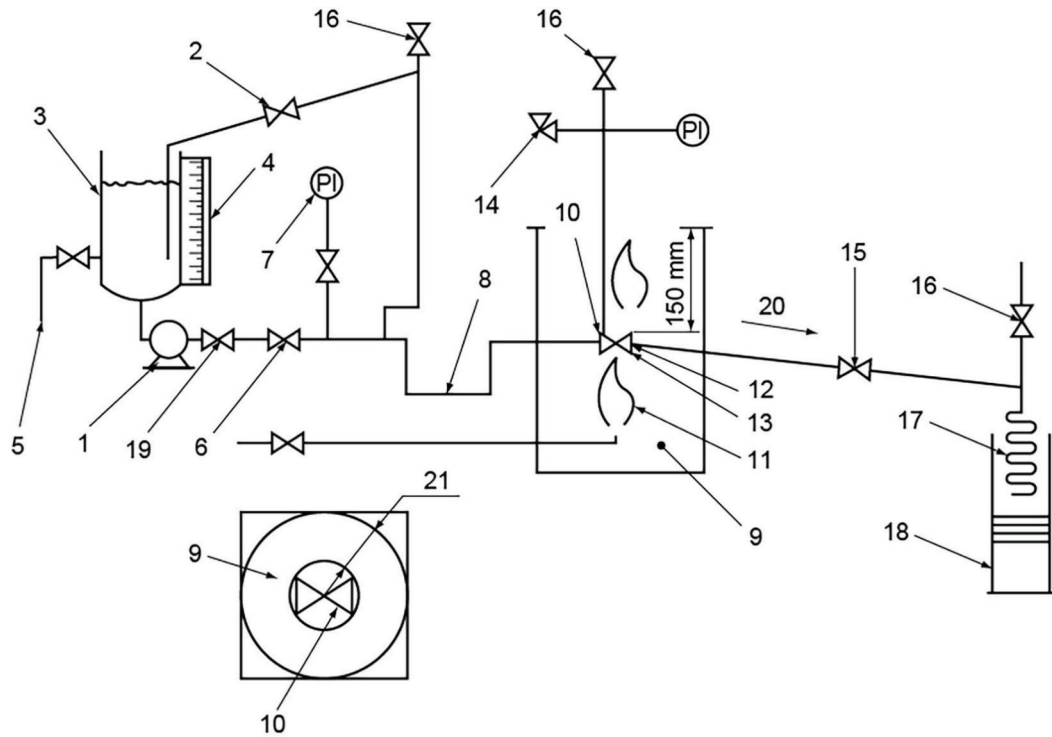

a) Pump as pressure source

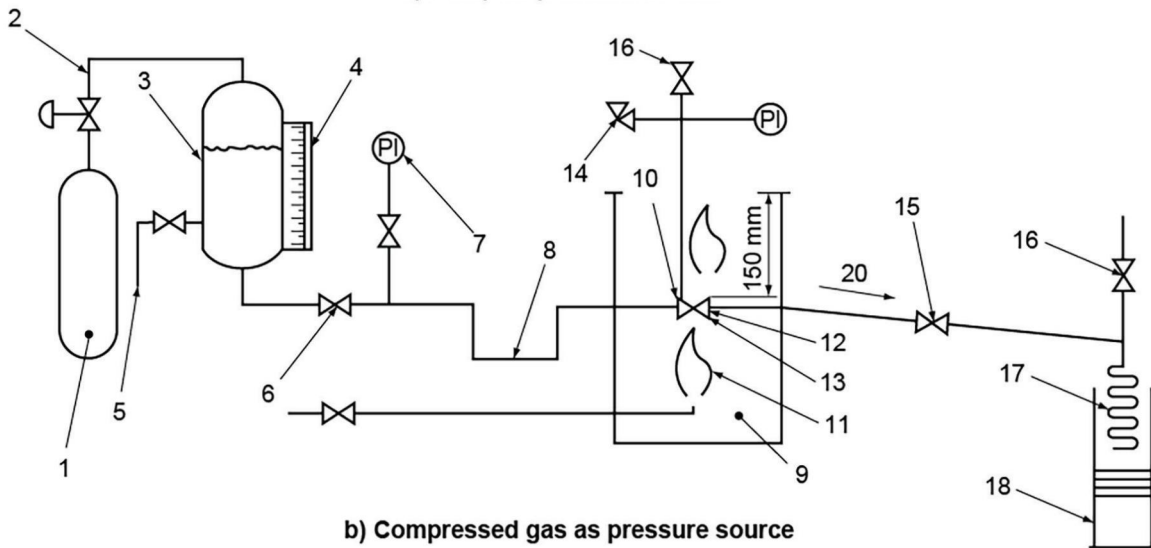

b) Compressed gas as pressure source

Key

- | | | |
|---------------------------------|---|------------------------------|
| 1 pressure source | 8 piping arranged to provide vapor trap (see 5.3.2) | 15 shut-off valve |
| 2 pressure regulator and relief | 9 enclosure for test | 16 vent valve |
| 3 vessel for water | 10 test valve mounted horizontally with stem in horizontal position (see 5.6.1) | 17 condenser |
| 4 calibrated sight gauge | 11 fuel gas supply and burners | 18 container (see 5.3.2) |
| 5 water supply | 12 calorimeter cubes (see 5.3.2) | 19 check valve |
| 6 shut-off valve | 13 flame environment and body thermocouples (see 5.3.2) | 20 slope |
| 7 pressure gauge | 14 pressure gauge and relief valve (see 5.3.2) | 21 clearance: 150 mm (6 in.) |

Figure 1—Recommended Systems

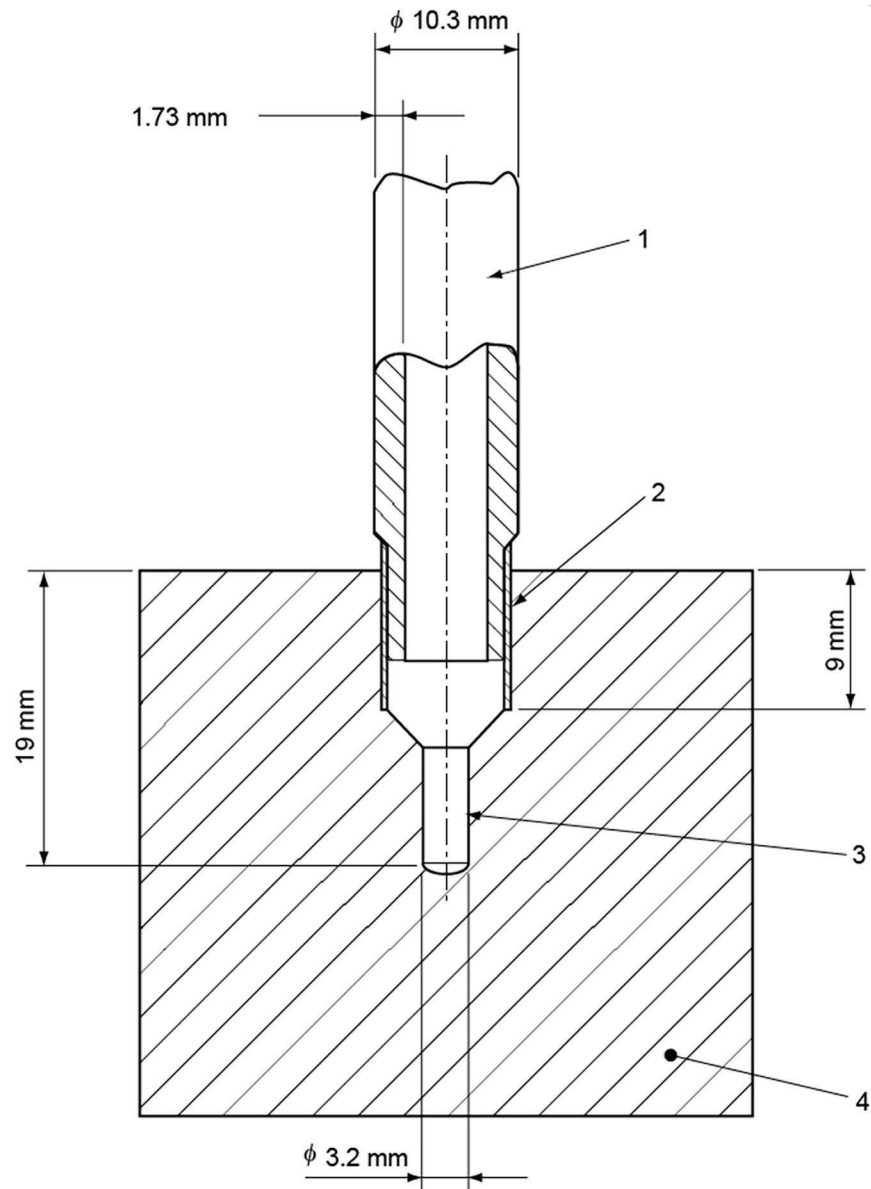

Key

- 1 pipe
- 2 pipe thread complying with ASME B1.20.1
- 3 thermocouple well
- 4 38 mm (1.5 in.) cube

Figure 2—Calorimeter Cube Design and Dimensions

5.4 Test Fluid

The test fluid used shall be water.

5.5 Test Fuel

The test fuel shall be liquid or gaseous.

5.6 Procedure

5.6.1 Mount the test valve in the test apparatus so that the stem and bore of the valve are in the horizontal position. Mount a valve that operates in only one direction (unidirectional) in the normal operating position of the valve. Locate the flame environment, body thermocouples, and calorimeter cubes in the positions shown in

Figures 3 and 4, as appropriate. For nonmetallic seated valves up to DN 100 (NPS 4) and pressure ratings up to Class 300, use two flame environment thermocouples, two body thermocouples, and calorimeter cubes as shown in Figure 3. For all other valves, use two flame environment thermocouples and two calorimeter cubes as shown in Figure 4. For valves DN 200 (NPS 8) and larger, use the third calorimeter cubes as shown in Figure 4.

5.6.2 With the test valve in the partially open position, open the valve on the water supply (key item 5 in Figure 1), the shut-off valve (key item 6), the vent valves (key item 16), and the shut-off valve (key item 15) in order to flood the system and purge the air. When the system is completely filled with water, close the shut-off valve (key item 15), the vent valves (key item 16), and the water supply valve (key item 5). Pressurize the system with water to a test pressure of 1.4 times the maximum allowable working pressure (+5 %, -0 %) at 20 °C (70 °F)—the actual test pressure may be rounded up to the next highest bar:

$$1 \text{ bar} = 0.1 \text{ MPa} = 10^5 \text{ Pa} = 14.5 \text{ psig}; 1 \text{ MPa} = 1 \text{ N/mm}^2$$

Check for leaks in the test apparatus and eliminate as necessary. Release the pressure, close the test valve, and open the shut-off valve (key item 15).

5.6.3 If the valve under test is of the upstream sealing type, determine the volume of water that is trapped between the upstream seat seal and the downstream seat seal when the valve is closed. Record this volume. It is assumed that during the fire test this volume of water will flow through the valve and pass the downstream seat seal to be collected in the container (key item 18 in Figure 1). Since this volume has not actually leaked through the upstream seat seal, it is deducted from the total volume collected in the downstream container when determining the through-seat leakage (see 5.6.12).

5.6.4 Pressurize the system to the appropriate pressure as specified below: for nonmetallic seated valves rated Class 150 and Class 300, the low test pressure at 0.2 MPa (30 psig); for all other valves, the high test pressure at 75 % of the maximum permissible seat working pressure at 20 °C (70 °F). Maintain this test pressure during the burn and cooldown periods. Momentary pressure losses of up to 50 % of the test pressure shall be permitted provided that the pressure recovers within two minutes and the cumulative duration is less than two minutes.

5.6.5 Record the reading on the calibrated sight gauge or device (see key item 4 in Figure 1). Empty the container (key item 18).

5.6.6 Adjust the test system, excluding the test valve, during the test period to maintain the temperatures and pressures required.

5.6.7 Open the fuel supply, establish a fire, and monitor the flame environment temperature throughout the burn period of 30 minutes, +5, -0 minutes. Check that the average temperature of the two flame environment thermocouples (key item 13 in Figure 1) reaches 750 °C (1400 °F) within two minutes from the start of the burn period, i.e. from ignition of the burners. Maintain the average temperature between 750 °C and 1000 °C (1400 °F to 1800 °F), with no reading less than 700 °C (1300 °F) for the remainder of the burn period of 30 minutes.

5.6.8 If cavity pressure exceeds the stated manufacturer's allowable pressure, the test shall end and be reported as an invalid test.

5.6.9 The average temperature of the calorimeter cubes shall be 650 °C (1200 °F) within 15 minutes of starting the burn period. For the remainder of the burn period, maintain the minimum average temperature of 650 °C (1200 °F), with no temperature falling to less than 560 °C (1000 °F). For valves subjected to the low-pressure test (see 5.6.4), the body thermocouple shall maintain 590 °C (1100 °F) for at least five minutes and the bonnet thermocouple shall maintain 650 °C (1200 °F) for at least 15 minutes of the burn period. The burn period may be extended by up to five minutes in order to achieve this requirement.

5.6.10 Record instrument readings (Figure 1 key items 7, 12, 13, and 14) every 30 seconds during the burn period. Thermocouples should be numbered, and individual records of temperature shall be recorded.

5.6.11 At the end of the burn period (30 minutes, +5, -0 minutes), shut off the fuel supply.

5.6.12 Immediately determine the amount of water collected in the container (key item 18 in Figure 1) and establish the total through-seat leakage during the burn period. If the test valve is an upstream sealing type (see 5.6.3), deduct the volume of water trapped between the upstream seat seal and the downstream seat seal. Continue collecting water in the container (key item 18) for use in establishing the external leakage rate of the test valve during the burn and cooldown periods.

5.6.13 Within five minutes of extinguishing the fire, force-cool the test valve with water so that its external surface temperature remains below 100 °C (212 °F); the time for forced cooling shall not exceed 10 minutes. Record the time taken to force-cool the external surface of the valve below 100 °C (212 °F).

WARNING The internal parts of the valve could remain at significantly higher temperatures than the external surface of the valve.

5.6.14 Check and adjust the test pressure in accordance with 5.6.4. Record the readings on the sight gauge (key item 4 in Figure 1) and determine the quantity of water in the container (key item 18). Record any leakage through the external pressure relief device if fitted as part of the standard design. The figures are used to calculate the total external leakage throughout the burn and cooldown periods.

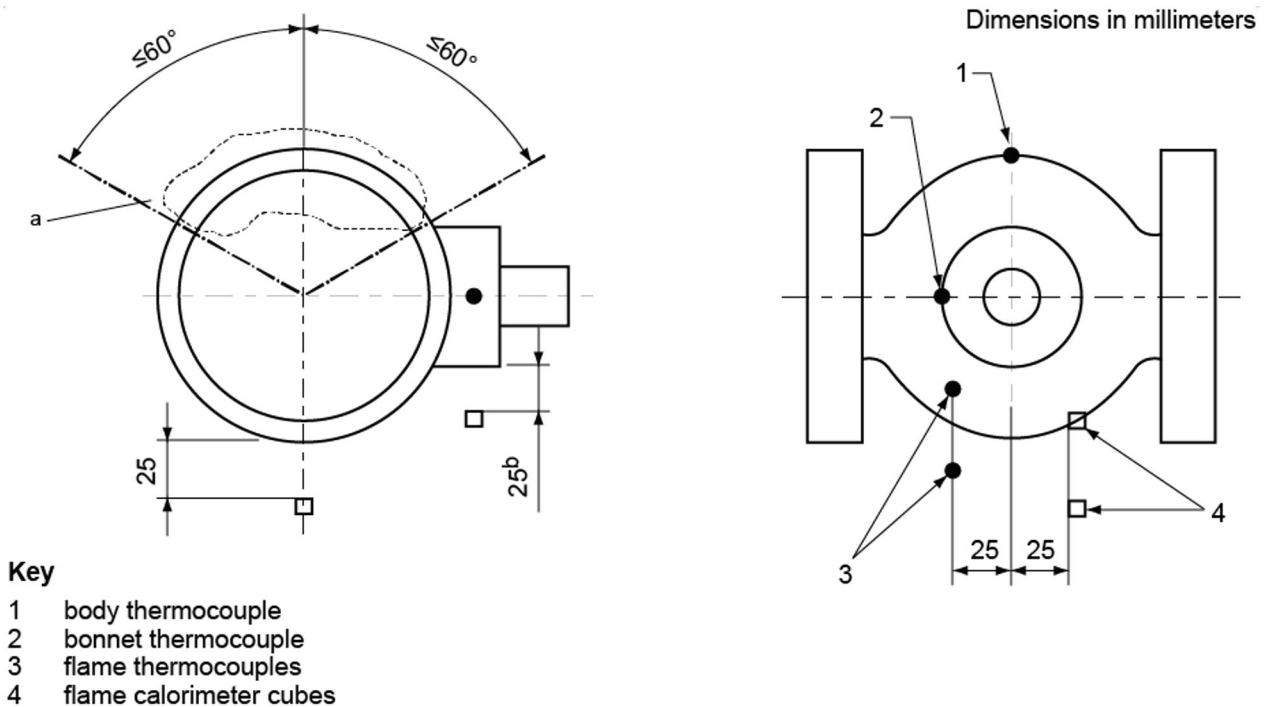

^a The body thermocouple is installed in this area. When installed, the body and bonnet thermocouples are recessed into the valve body/bonnet a distance of $\frac{1}{2}$ the thickness of the wall or 13 mm (0.5 in.), whichever is the lesser.

^b From the stem seal.

Figure 3—Location of Temperature Measurement Sensors—Nonmetallic Seated Valves up to DN 100 (NPS 4), NPS 4, Class 150, and Class 300

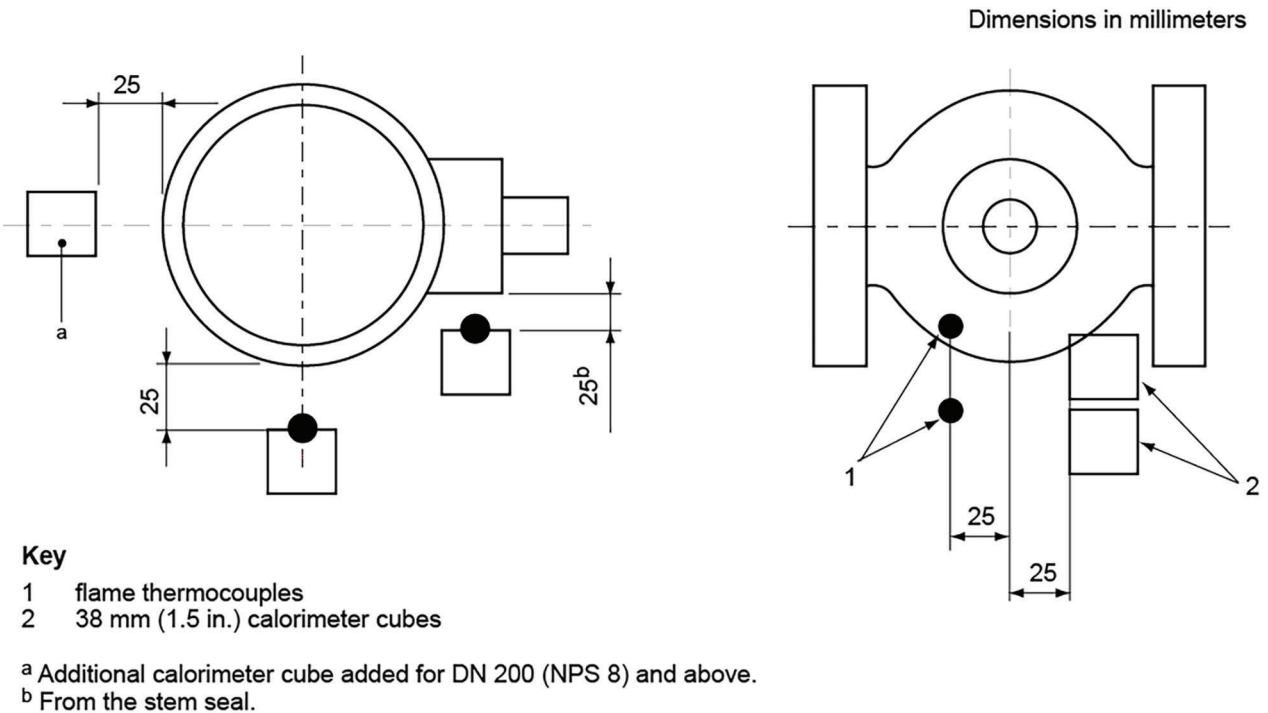

Figure 4—Location of Temperature Measurement Sensors for All Other Valves (Not Described in Figure 3)

5.6.15 For valves Class 600 and lower, decrease or stabilize the pressure to the low test pressure at 0.2 MPa (30 psig) and measure the through-seat leakage over a five-minute period.

5.6.16 After completing the static leakage tests (5.6.12 through 5.6.15), close the shut-off valve (Figure 1, key item 15), operate the test valve against the low test pressure at 0.2 MPa (30 psig) to the fully open position and then to the fully closed position. Open the shut-off valve (Figure 1, key item 15). Allow the system to stabilize for a five-minute period, and once completed, record in the test report the through-seat leakage over a five-minute time period.

5.6.17 Increase or stabilize the test pressure to the high test pressure, close the shut-off valve (15), and operate the test valve against the test pressure to the fully open position.

5.6.18 Stabilize the pressure to the high test pressure and measure the external leakage over a five-minute period.

5.6.19 See Annex A for valve requiring testing for external leakage only.

6 Performance

6.1 General

Valves tested in accordance with Section 5 shall be in accordance with the criteria of 6.2 to 6.7.

6.2 Through-seat Leakage during Burn Period

For the low-pressure test, the average through-seat leakage at low test pressure during the burn period (see 5.6.11) shall not exceed the value given in Table 1. For the high-pressure test, the average through-seat leakage at high test pressure during the burn period (see 5.6.11) shall not exceed the value given in Table 1.

6.3 External Leakage during Burn and Cooldown Periods

For the low-pressure test, the average external leakage, not including through-seat leakage, during the burn and cooldown periods (see 5.6.13) shall not exceed the value given in Table 1. For the high-pressure test, the average external leakage, not including through-seat leakage, during the burn and cooldown periods (see 5.6.13) shall not exceed the value given in Table 1. External leakage can be measured by calculating difference between quantity of supply water (key item 4 in Figure 1) used during test and through-seat leakage collected in container (key item 18).

6.4 Low-pressure Test Through-seat Leakage after Cooldown

The maximum through-seat leakage shall not exceed the value given in Table 1.

6.5 Operability

The valve shall be cycled from the fully closed to the fully open position using the operator fitted to the test valve. Due to the temperature of the test, high pressures within the valve may be at a level that may compromise the pressure boundary integrity. Extension handles are allowed to protect the operating personnel from risks associated with potential loss of containment during the valve operation. The use of extension handles shall not result in an applied torque that is higher than that available from the fitted operator.

6.6 External Leakage Following Operational Test

The average external leakage of the valve in the open position at the high test pressure (see 5.6.18) shall not exceed the value given in Table 1.

Table 1—Maximum Leak Rates

DN	NPS	Through-seat Leakage (All leakage in mL/min)			External Leakage (All leakage in mL/min)		
		During Burn (See 5.6.11 and 6.2)		After Cooldown (See 5.6.15, 5.6.16 and 6.4)	During Burn and Cooldown (See 5.6.13 and 6.3)		After Operational Test (See 5.6.18 and 6.6)
		Low Test Pressure	High Test Pressure	Low Test Pressure	Low Test Pressure	High Test Pressure	High Test Pressure
8	¼	32	128	13	8	32	8
10	⅜	40	160	16	10	40	10
15	½	60	240	24	15	60	15
20	¾	80	320	32	20	80	20
25	1	100	400	40	25	100	25
32	1¼	128	512	51	32	128	32
40	1½	160	640	64	40	160	40
50	2	200	800	80	50	200	50
65	2½	260	1040	104	65	260	65
80	3	320	1280	128	80	320	80
100	4	400	1600	160	100	400	100
125	5	500	2000	200	125	500	125
150	6	600	2400	240	150	600	150
200	8	800	3200	320	200	800	200
>200	>8	800	3200	320	200	800	200

NOTE External leakage does not include potential leakage from the pipework-to-valve end connection (see 5.3.1).

6.7 Test Report

The test report shall include the following information:

- a) date of fire test;
- b) place at which the fire test was conducted;
- c) specification used for the fire test (including date of publication and applicable amendments);
- d) valve manufacturer's name and address;
- e) statement that the fire-tested valve has passed all the required hydrostatic, air type, and production pressure tests required by the standard to which the valve was manufactured (manufacturer's statement may be accepted);
- f) full description of the valve tested, including nominal size, pressure rating designation, type (e.g. gate), weight, whether reduced or full bore, material of body/bonnet, trim material, and manufacturer's reference number;
- g) markings on the valve and their locations, including manufacturer's nameplate date (if fitted);
- h) manufacturer's sectional drawing of the valve and a detailed parts list, including materials, of all valve components tested, identified in the text by identification number (drawing number), and revision and date of issue of documents;
- i) statement as to whether or not a gear box is fitted to the test valve and, if fitted, the type, manufacturer's name, model number, and mechanical advantage;
- j) test pressure during burn and cooldown;
- k) time of test start, i.e. of ignition of burners;
- l) temperature recorded at start and at 30-second intervals throughout duration of test, with individual records for each thermocouple;
- m) through-seat leakage during burn period (see 6.2);
- n) external leakage during burn and cooldown periods (see 6.3);
- o) time required for valve to cool to 100 °C;
- p) through-seat leakage (low-pressure test) for valves Class 600 and lower;
- q) external leakage in the open position (see 5.6.18);
- r) valve through-seat leakage from testing in 5.6.16;
- s) whether the valve is asymmetric and intended for bidirectional installation—test results in both directions;
- t) observations made during the course of the test that may have bearing on the results provided, including reference to the operability of the valve if the fully open position in 5.6.16 was not achieved during the cycle test;
- u) declaration as to whether or not the test valve complied with the requirements of this standard;

- v) indication on the cover sheet or table of contents of the report of the total number of pages contained in the document (including drawings), with each page being numbered, e.g. 1/12, 2/12;
- w) name and affiliation of individuals witnessing the fire test;
- x) manufacturer's reported maximum allowable body cavity pressure.

7 Qualification of Other Valves by Representative Size, Pressure Rating, and Materials of Construction

7.1 General

All valves of the same basic design (type, model, and/or configuration) as the test valve may be deemed to have been fire-tested, subject to the following limitations.

- a) A test valve may be used to qualify valves larger than the test valve but not exceeding twice the nominal size of the test valve (see 7.3). A size DN 200 or NPS 8 test valve qualifies all larger sizes. If the minimum size of a given range of valves is greater than DN 200 or NPS 8, then the minimum size of the range shall be tested to qualify all sizes.
- b) A DN 50 (NPS 2) valve may be used to qualify all smaller sizes of valve of the same types. If the maximum size of a given range of valves is smaller than DN 50 or NPS 2, then the maximum size of the range shall be tested to qualify all sizes.
- c) A test valve may be used to qualify valves with higher class ratings but not exceeding twice the class rating of the test valve, except as shown in Tables 3 and 4.
- d) A reduced-bore test valve may be used to qualify a smaller nominal size full-bore valve when the components associated with the closure member, seat seals, and stem are identical in design and size. In such a case, the permissible average leakage rates are those applicable to the full-bore valve per Table 1 based on the valve NPS.
- e) The type of valve body ends is not considered by this standard. However, the mass of the valve is determined in part by the body end type. For qualification to the present standard, and providing that all other qualification criteria have been met, valves with ends different to those of the test valve may also qualify provided that their mass is greater than that of the test valve or their mass is not less than 75 % of that of the test valve.

7.2 Materials of Construction

7.2.1 For the purposes of product compliance certification or type-testing systems, the materials of construction of the pressure-retaining envelope of the valve shall be deemed to qualify other materials of construction within the generic classifications below, including but not limited to the listed material within each classification;

- ferritic, ASME B16.34 material groups 1.1 through 1.18;
- austenitic, ASME B16.34 material groups 2.1 through 2.5;
- duplex, ASME B16.34 material groups 2.6 through 2.12;
- nickel alloys, ASME B16.34 material group 3.

7.2.2 If a range of valves is covered by testing of ferritic test valves, then the type-testing coverage may be extended to cover austenitic, duplex, or nickel alloy materials by carrying out a further test on a single valve of each generic material and class range per Table 4. For product lines DN 50 (NPS 2) and below, the valve shall be of the maximum size of the product range. For those where the product line extends to larger sizes, the valve shall be equal to or greater than the median size in the ferritic testing. Other materials of construction of

the pressure-retaining envelope of the valve require full testing of representative size and pressure ratings as specified in 7.3 and 7.4.

7.2.3 Alloy steel bolting (e.g. B7 or L7) used as part of the valve's pressure-retaining envelope may be used to qualify austenitic steel bolting but not vice versa.

7.2.4 Any change in nominal composition of nonmetallic materials with respect to the seat-to-closure member seal, seat-to-body seal, stem seal, or body joint seal requires a requalification. Filled PTFE, however, may qualify nonfilled PTFE and vice versa. Retest of a single valve equal to or greater than the median size of the previously tested product range is allowed for requalification for a change in a manufacturer of packing material.

7.2.5 Change of an elastomeric material type (e.g. FKM or HNBR) in the valve requires a retest of a single valve equal to or greater than the median size of the previously tested product range.

7.3 Qualification of Valves by Nominal Size

Testing of one size of a product family shall validate other product sizes as per Tables 2 and 3.

7.4 Qualification of Valves by Pressure Rating

Testing of one pressure class of a product family shall validate other products as per Table 4.

Table 2—Other Valves Qualified by DN

Size of Valve to Be Tested DN	Other Valve Sizes Qualified DN
50	50 and below; 65; 80; 100
65	65; 80; 100; 125
80	80; 100; 125; 150
100	100; 125; 150; 200
125	125; 150; 200; 250
150	150; 200; 250; 300
200	200 and larger

Table 3—Other Valves Qualified by NPS

Size of Valve to Be Tested NPS	Other Valve Sizes Qualified NPS
2	2 and below; 2½; 3; 4
2½	2½; 3; 4; 5
3	3; 4; 5; 6
4	4; 5; 6; 8
5	5; 6; 8; 10
6	6; 8; 10; 12
8	8 and larger

Table 4—Other Valves Qualified by Class

Valve Tested Class Rating	Other Valves Qualified Class Rating
150	150; 300
300	300; 400; 600
400	400; 600; 800
600	600; 800; 900
800	800; 900; 1500
900	900; 1500
1500	1500; 2500
2500	2500

Annex A (informative)

External Leakage Only Modified Test Procedures

A.1 General Statement

A.1.1 This annex provides information for products requiring modified test procedures or for products outside the scope of the main document. This includes valves that are tested for external leakage only. Reports and/or certificates produced for these tests shall clearly state that these are “API 607-modified for external leakage only” tests.

A.1.2 Valves, such as elasto/polymer lined plug valves, control valves and others, when requested by the purchaser, may be tested per this procedure.

A.2 Exceptions to Standard

The following paragraphs outline the changes to the procedure. They are listed by the respective subsection number in the main body that these paragraphs are intended to replace:

- a) 5.6.2—With the test valve in the partially open position, open the water supply valve (key item 5 in Figure 1), the shut-off valve (key item 6), the vent valves (key item 16), and the shut-off valve (key item 15) to flood the system and purge the air. When the system is completely filled with water, close the shut-off valve (key item 15), the vent valves (key item 16), and the valve on the water supply (key item 5). Pressurize the system with water to a test pressure of 1.4 times the maximum allowable working pressure at 20 °C (70 °F)—the actual test pressure may be rounded up to the next highest bar:

$$1 \text{ bar} = 0.1 \text{ MPa} = 10^5 \text{ Pa} = 14.5 \text{ psig}; 1 \text{ MPa} = 1 \text{ N/mm}^2$$

Check for leaks in the test apparatus and eliminate as necessary. Release the pressure, keep test valve open, and close the shut-off valve (key item 15).

- b) 5.6.4—Pressurize the system to 75 % of the CWP in all cases, regardless of seat materials.
- c) 5.6.15—Do not perform.
- d) 5.6.16—Do not perform.
- e) 5.6.17—Stabilize the test pressure to the high test pressure, keep the shut-off valve (key item 15 in Figure 1) closed, and operate the test valve with the test pressure to the closed and back to the fully open position.
- f) Add to 6.7 c)—Specification used for the fire test (including date of publication and applicable amendments, “API 607 – 8th Edition – Modified” test).

Bibliography

The following codes and standards are not referenced directly in this standard. Familiarity with these documents may be useful as they provide additional information pertaining to this standard. For dated references, only the edition cited applies. For undated references, the latest edition of the referenced document (including any amendments) applies.

- [1] API Recommended Practice 591, *Process Valve Qualification Procedure*
- [2] API Specification 6D, *Specification for Valves*
- [3] API Standard 599, *Metal Plug Valves—Flanged, Threaded, and Welding Ends*
- [4] API Standard 608, *Metal Ball Valves—Flanged, Threaded, and Welding Ends*
- [5] API Standard 609, *Butterfly Valves: Double-flanged, Lug- and Wafer-Type, and Butt-welding Ends*
- [6] ASME B1.20.1, *Pipe Threads, General Purpose (Inch)*
- [7] ASME B16.34, *Valves—Flanged, Threaded, and Welding End*



200 Massachusetts Avenue, NW
Suite 1100
Washington, DC 20001-5571
USA

202-682-8000

Additional copies are available online at www.api.org/pubs

Phone Orders: 1-800-854-7179 (Toll-free in the U.S. and Canada)
303-397-7956 (Local and International)
Fax Orders: 303-397-2740

Information about API publications, programs and services is available on the web at www.api.org.

Product No. C60708